

COUPE A-A
ECHELLE 1 : 10

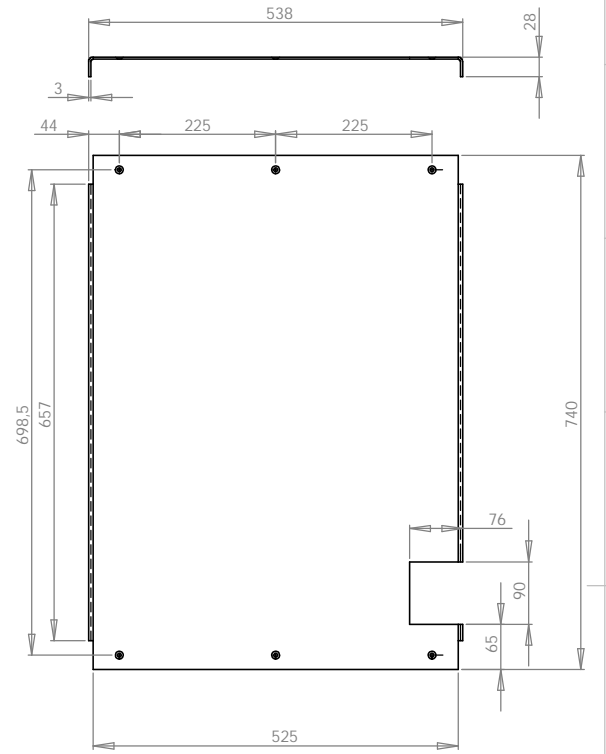
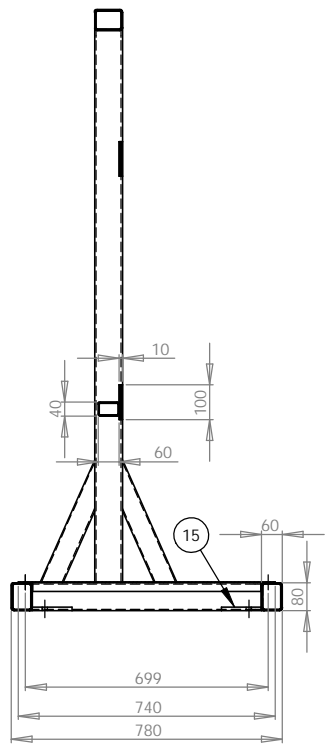

No ARTICLE	QTE	DESCRIPTION	DIMENSIONS	NORME
1	1	Tube ISO 60x40x3		376
2	1	Tube ISO 60x40x3		376
3	1	Tube ISO 60x40x3		1630
4	1	Tube ISO 60x40x3		376
5	1	Tube ISO 60x40x3		376
6	1	Tube ISO 60x40x3		1070
7	1	Tube ISO 60x40x3		1290
8	1	Tube ISO 80x60x4		1645
9	1	Tube ISO 80x60x4		1750
10	1	Tube ISO 80x60x4		1645
11	1	Tube ISO 80x60x4		780
12	1	Tube ISO 80x60x4		1750
13	1	Tube ISO 80x60x4		780
14	1	Tube ISO 80x60x4		1750
15	4	Plat 60 X10		165
16	1	Toile gaufrage C 30/10	740 X 580	
17	2	Plat 100 X10		320
18	2	Toile 30/10	740 X 580	

Licence étudiante de SolidWorks
Utilisation universitaire uniquement

Echelle: BACCALAUREAT DE TECHNICIEN EN CHAUDRONNERIE INDUSTRIELLE

SECHEUR D'HYDROGENE

BÂTI

Format: A2

Dessiner par: J.DESMAELE date: 09/2009